



**IC Pneumatic
Forklift Trucks**
6.0 – 7.0 tonnes



**FD60
FD70**

Characteristics					
1.1	Manufacturer (abbreviation)			Mitsubishi	Mitsubishi
1.2	Manufacturer's model designation			FD60	FD70
1.3	Power source: (battery, diesel, LP gas, petrol)			Diesel	Diesel
1.4	Operator type: pedestrian, (operator)-standing, -seated			Seated	Seated
1.5	Load capacity	Q	(kg)	6000	7000
1.6	At load centre	c	(mm)	600	600
1.8	Load distance	x	(mm)	585	585
1.9	Wheelbase	y	(mm)	2300	2300
Weight					
2.1	Truck weight, without load / including battery (simplex mast, lowest lift height)		kg	8715	9325
2.2	Axle loading with maximum load, front/rear (simplex mast, lowest lift height)		kg	13255/1460	14660/1665
2.3	Axle loading without load, front/rear (simplex mast, lowest lift height)		kg	4160/4555	4050/5275
Wheels, Drive Train					
3.1	Tyre type: V=solid, L=pneumatic, SE=solid pneumatic - front/rear			L	L
3.2	Tyre dimensions, front			8.25X15-12PR	8.25X15-12PR
3.3	Tyre dimensions, rear			8.25X15-12PR	8.25X15-12PR
3.5	Number of wheels, front/rear (x=driven)			4X / 2	4X / 2
3.6	Track width (centre of tyres), front	b10	(mm)	1650	1650
3.7	Track width (centre of tyres), rear	b11	(mm)	1650	1650
Dimensions					
4.1	Mast tilt, forwards/backwards	α/β	$^{\circ}$	6/12	6/12
4.2	Height with mast lowered (see tables)	h1	(mm)	3070	3070
4.3	Free lift (see tables)	h2	(mm)	200	200
4.4	Lift height (see tables)	h3	(mm)	4000	4000
4.5	Overall height with mast raised	h4	(mm)	5280	5280
4.7	Height to top of overhead guard	h6	(mm)	2420	2420
4.8	Seat height	h7	(mm)	1350	1350
4.12	Tow coupling height	h10	(mm)	485	485
4.19	Overall length	l1	(mm)	4855	4855
4.20	Length to fork face (includes fork thickness)	l2	(mm)	3590	3635
4.21	Overall width	b1/b2	(mm)	2175	2175
4.22	Fork dimensions (thickness, width, length)	s / e / l	(mm)	60/150/1220	60/150/1220
4.23	Fork carriage to DIN 15 173 A/B/no			IV A / No	IV A / No
4.24	Fork carriage width	b3	(mm)	1780	1780
4.31	Ground clearance under mast, with load	m1	(mm)	140	140
4.32	Ground clearance at centre of wheelbase, with load (forks lowered)	m2	(mm)	255	255
4.33	Working aisle width with 1000 x1200 mm pallets, crosswise	Ast	(mm)	5095	5180
4.34	Working aisle width with 800 x1200 mm pallets, crosswise	Ast	(mm)	4895	4980
4.35	Turning circle radius	Wa	(mm)	3310	3395
4.36	Minimum distance between centres of rotation	b13	(mm)	1260	1260
Performance					
5.1	Travel speed, with/without load		km/h	23.0/27.5	22.0/27.5
5.2	Lifting speed, with/without load		m/s	0.44/0.47	0.44/0.47
5.3	Lowering speed, with/without load		m/s	0.55/0.55	0.55/0.55
5.5	Rated drawbar pull, with/without load		N	42800/28700	42700/27700
5.7	Gradeability, with/without load		%	31 / 29	27 / 27
5.9	Acceleration time (10 metres) with/without load		s	-	-
5.10	Service brakes (mechanical/hydraulic/electric/pneumatic)			Hydraulic	Hydraulic
IC Engine					
7.1	Manufacturer / Type			Mitsubishi/S6S-T	Mitsubishi/S6S-T
7.2	Rated output B to ISO 1585		kW	69,9	69,9
7.3	Rated speed to DIN 70 020		rpm	2300	2300
7.4	Number of cylinders / cubic capacity		cm ³	6/4996	6/4996
7.5	Fuel consumption according to VDI cycle		l/h / kg/h	-	-
Miscellaneous					
8.1	Type of drive control			Torque converter	Torque converter
8.2	Maximum operating pressure for attachments		bar	191	191
8.3	Oil flow for attachments		l/min	-	-
8.4	Noise level, mean value at operator's ear		dB(A)	-	-
8.5	Towing coupling design / DIN type, ref.			-	-

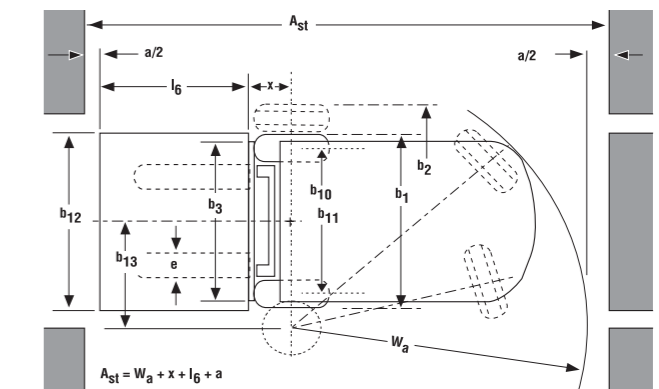
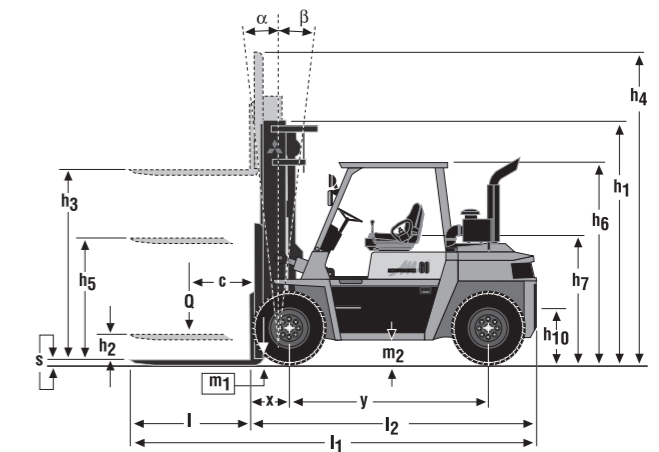

$A_{st} = W_a + x + l_6 + a$
 A_{st} = Working aisle width with load
 a = Safety clearance (200 mm)
 l_6 = Pallet length (800 or 1000 mm)
 b_2 = Pallet width (1200 mm)



Mast Performance and Capacity

Mast type	FD60 • FD70					FD60	FD70
	h3 mm	h1 mm	h4 mm	h2 mm	h5 mm	Q @ 600mm kg	Q @ 600mm kg
Simplex	3000	2570	4280	200	-	6000	7000
	3300	2720	4580	200	-	6000	7000
	3500	2820	4780	200	-	6000	7000
	3700	2920	4980	200	-	6000	7000
	4000	3070	5280	200	-	6000	7000
	4500	3320	5780	200	-	6000	7000
	5000	3670	6280	200	-	6000	7000
	5500	3920	6780	200	-	5800	6700
	6000	4170	7280	200	-	5600	6400
	6500	4420	7780	200	-	5400	6200
	6600	4470	7880	200	-	5000	5800
7000	4670	8280	200	-	4200	5000	
Triplex	3700	2375	4980		1095	5500	6200
	4000	2475	5280		1195	5500	6200
	4300	2575	5580		1295	5500	6200
	4500	2645	5790		1365	5500	6200
	4700	2725	5980		1445	5400	6200
	5000	2825	6280		1545	5300	6200
	5500	3075	6780		1795	5100	6000
	6000	3245	7290		1965	4900	5700
	6500	3425	7780		2145	4700	5400
	7000	3575	8280		2295	4300	4600
	7500	3745	8790		2465	3600	3800
8000	3925	9280		2645	2900	3100	

- h1 Height with mast lowered
- h2 Standard free lift
- h3 Lift height
- h4 Height with mast raised
- h5 Full free lift
- Q Lifting capacity, rated load
- c Load centre (distance)

(Consult your distributor for the maximum back tilt allowed to obtain the capacities specified.)



CESM0975 (11/07)
© 2007 MCFE
Printed in The Netherlands

mitforklift@mcf.nl
www.mitforklift.com

NOTE: Performance specifications may vary depending on standard manufacturing tolerances, vehicle condition, types of tyres, floor or surface conditions, applications or operating environment. Trucks may be shown with non-standard options. Specific performance requirements and locally available configurations should be discussed with your distributor of Mitsubishi forklift trucks. Mitsubishi follows a policy of continual product improvement. For this reason, some materials, options and specifications could change without notice.

Main features

The Mitsubishi rugged range of 6.0 to 7.0 ton diesel engine trucks: built to last, easy to maintain...

- *Access to the operator's compartment is easy thanks to the conveniently placed grab bars and footsteps.*
- *The tilting steer column, adjustable seat and generous foot and leg room ensure a relaxed driving position for all operators.*
- *The comprehensively equipped instrument panel provides valuable on-the-go information and warning signals to the driver, allowing maximum control.*
- *Small diameter steering wheel, tilting steer column and full hydrostatic steering for precise and responsive manoeuvring.*
- *The trunnion mounted, oscillating steer axle ensures a comfortable ride and excellent ground contact - even on the poorest work surfaces.*
- *Use of small diameter lift cylinders and strategic locating of hydraulic lines ensure excellent forward visibility through the wide mast.*
- *Robust chassis and heavy duty steer axle invite long life and high performance.*
- *The powerful 6 cylinder S6S diesel engine is designed to the highest standards. It is quiet and fuel efficient. This engine exceeds EURO level III A emission regulations.*
- *Tough rubber engine mounting blocks and virtually eliminate vibrations to the operator's compartment.*
- *For safe and efficient braking, these models are fitted with vacuum assisted hydraulic brakes.*
- *Two-speed automatic transmission.*
- *Easy service keeps your machine in sound working condition; routine maintenance is performed quickly: Engine, radiator, coolant recovery bottle, engine oil dipstick, fuel shut-off valve, air cleaner and battery are all within easy view and reach.*
- *Strong gas cylinders assist in raising the engine hood for access to all maintenance check points.*
- *Front engine cover and floor plate remove for rapid access to the transmission and torque converter.*
- *Axle and mast lubrication points are easy to reach. Mast and carriage load rollers are permanently lubricated.*

when **reliability** is **everything**

Developed for outstanding performance and genuine value for money, the awardwinning* range of Mitsubishi forklift trucks and warehouse equipment is built to a higher specification to maximize productivity and ensure utter reliability... whatever the application.

It's what you'd expect from one of the world's largest corporations whose companies are at the leading edge of technologies where performance, quality and dependability can never be compromised.

It means that, from a single safe source, we can meet 98% of all handling requirements, supplied to you via a range of competitive finance options including outright purchase, rental or leasing. So your local dealer can advise you on precisely the right product for your application... and your budget.

Moreover, because we understand how much you depend on your Mitsubishi forklift truck, we deliver the highest levels of customer support.

Through a network of carefully selected dealerships, we provide quality maintenance and customer care programmes including a choice of warranties that give complete peace of mind. Every dealership holds extensive stocks of manufacturer-approved parts, backed by a central store that holds literally millions of items constantly in stock and achieves a first-pick fulfilled rate of 97%. So your truck can be fixed first time, virtually every time.

You can find your nearest dealer at
www.mitforklift.com

** Mitsubishi Forklift Trucks has won **four** separate Fork Lift Truck Association Annual Awards for Excellence covering the areas of **Ergonomics**, the **Environment** and **Innovation**.*

